

"GATES"[®] POLY CHAIN[®]

GT2 BELTS

The **POLY CHAIN[®] GT2** synchronous belts represent the most recent development of the "GATES"[®] range and provide excellent performance on industrial drives with high torque and low speed. The belt's reverse surface and the teeth are made using a polyurethane mix and ensure special adhesion to the drive body. This particular type of polyurethane renders the belt resistant and virtually immune to abrasion and attack by chemical agents. The aramide strands give the belt extraordinary transmission capacity and excellent resistance to wear.

The belts have a very long useful working life and operate perfectly at temperatures lying between -54°C and + 85°C.

Both the belts and the pulleys are manufactured with the following pitches: 8mm - 8MGT and 14mm - 14 MGT.

Belt characteristics

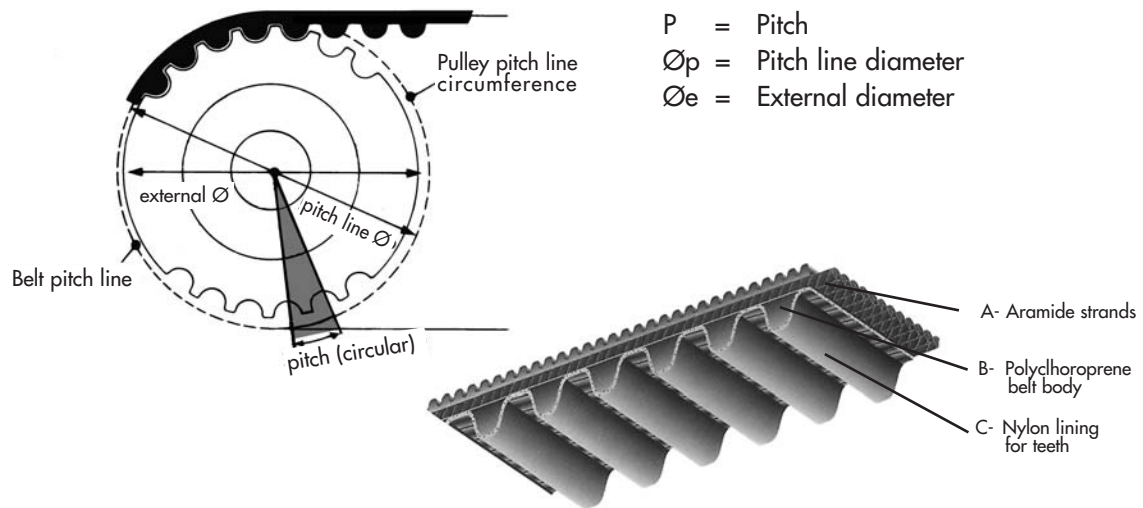

Belt identification

8MGT Pitch in mm.
 1280 Pitch line extension
 36 Belt width

} 8MGT - 1280 - 36

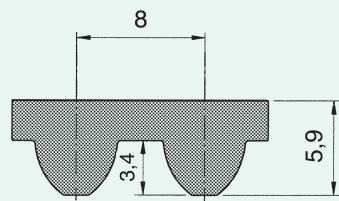

Type: 8MGT

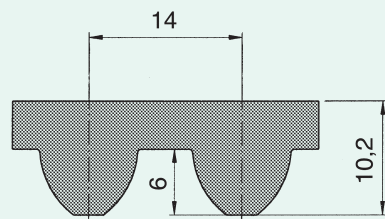

Type: 14MGT

"GATES"® POLY CHAIN® - GT2 BELTS

PITCH SELECTION FOR POLY CHAIN GT2 BELT

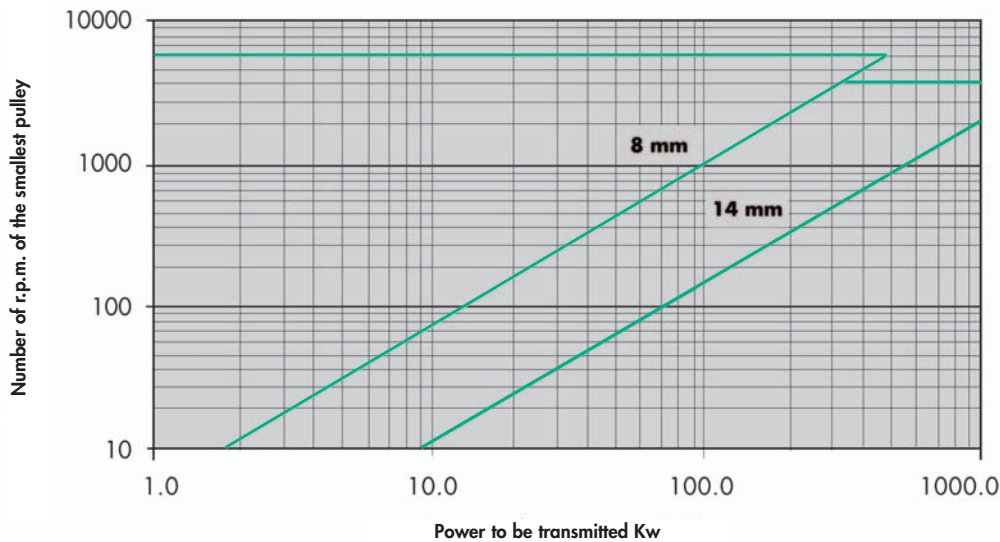

POLY CHAIN GT2 BELT WIDTHS

PITCH	8MGT	14MGT		
BELT WIDTHS mm.	12	20		
	21	37		
	36	68		
	62	90		
		125		

8MGT (8mm. pitch)

No. of Teeth	Pitch line length	Belt type
80	640	8MGT-640
95	720	8MGT-720
100	800	8MGT-800
112	896	8MGT-896
125	1000	8MGT-1000
140	1120	8MGT-1120
150	1200	8MGT-1200
160	1280	8MGT-1280
180	1440	8MGT-1440
200	1600	8MGT-1600
224	1792	8MGT-1792
250	2000	8MGT-2000
280	2240	8MGT-2240
300	2400	8MGT-2400
315	2520	8MGT-2520
355	2840	8MGT-2840
400	3200	8MGT-3200
450	3600	8MGT-3600
500	4000	8MGT-4000
560	4480	8MGT-4480

14MGT (14mm. pitch)

No. of Teeth	Pitch line length	Belt type
71	994	14MGT-994
80	1120	14MGT-1120
85	1190	14MGT-1190
90	1260	14MGT-1260
100	1400	14MGT-1400
112	1568	14MGT-1568
125	1750	14MGT-1750
135	1890	14MGT-1890
140	1960	14MGT-1960
150	2100	14MGT-2100
160	2240	14MGT-2240
170	2380	14MGT-2380
180	2520	14MGT-2520
190	2660	14MGT-2660
200	2800	14MGT-2800
224	3136	14MGT-3136
236	3304	14MGT-3304
250	3500	14MGT-3500
280	3920	14MGT-3920
315	4410	14MGT-4410