

WELDABLE HUBS FOR TAPER-LOCK® BUSH

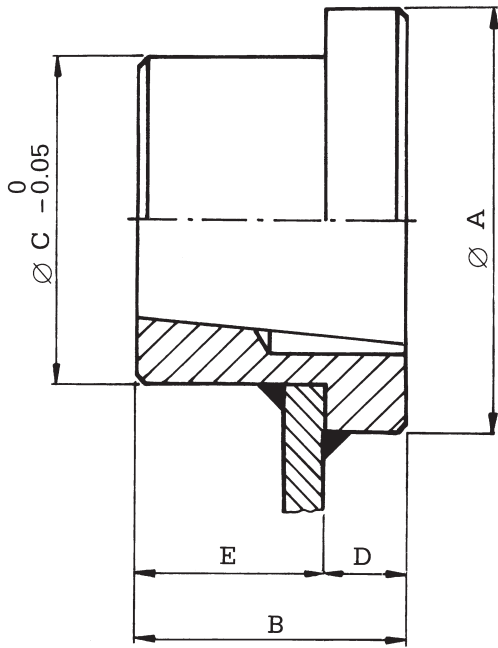

MATERIAL: Fe 50

TYPE	BUSH	ØA	B	ØC	D	E
MS. T. L. 1210	1210	70	25	65	9	16
MS. T. L. 1610	1610	80	25	75	9	16
MS. T. L. 2012	2012	95	32	90	12	20
MS. T. L. 2517	2517	115	45	110	19	26
MS. T. L. 3020	3020	145	51	140	19	32
MS. T. L. 3030	3030	145	76	140	19	57
MS. T. L. 3525	3525	190	65	180	25	40
MS. T. L. 3535	3535	190	89	180	25	64
MS. T. L. 4040	4040	200	102	190	32	70
MS. T. L. 4545	4545	220	115	205	38	77
MS. T. L. 5050	5050	240	127	220	38	89

TAPER HUBS

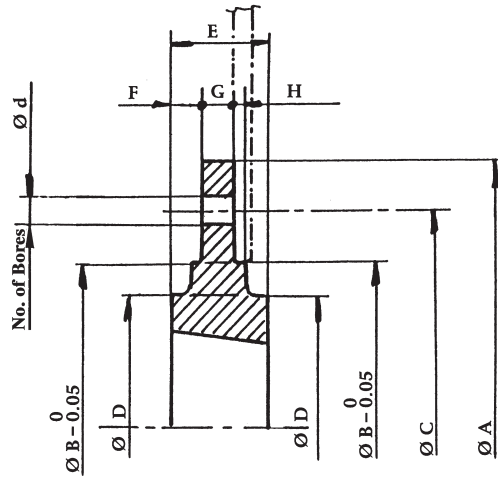

TYPE

CAST IRON

TYPE	BUSH	ØA	ØB	ØC	ØD	E	F	G	H	No. of bores	Ød
MSM T.L. Ø 120	1210	120	80	100	70	25	9	7.5	2.5	6	7.5
MSM T.L. Ø 130	1610	130	90	110	80	25	9	7.5	2.5	6	7.5
MSM T.L. Ø 145	2012	145	115	125	95	32	12	9.5	2.5	6	9.5
MSM T.L. Ø 185	2517	185	130	155	115	45	19	12.5	2.5	6	11.5
MSM T.L. Ø 220	3020	220	165	190	145	51	19	12.5	2.5	6	13.5

TYPE

CAST IRON - (*) STEEL

TYPE	BUSH	ØA	ØB	ØC	ØD	E	F	G	H	No. of bores	Ød
MSM T.L. Ø 180	1210	180	90	135	75	25	9.25	6.5	2.5	6	7.5
MSM T.L. Ø 200	1615	200	110	150	85	38	15.3	7.5	2.5	6	7.5
MSM T.L. Ø 270	2012	270	140	190	110	32	11.8	8.5	2.5	6	9.5
MSM T.L. Ø 340	2517	340	170	240	125	45	17.8	9.5	2.5	8	11.5
MSM T.L. Ø 430	3020	430	220	300	160	51	18.8	13.5	2.5	8	13.5
(*)MSM T.L. Ø 485	3020	485	250	340	160	51	18.8	13.5	2.5	8	13.5